

Motic®

AE30/31

INVERTED MICROSCOPE

Motic combines CCIS optics with innovative mechanical design, unrivalled versatility, ergonomics and optical excellence and brings you a new series of inverted microscopes.



AE31



THE MOTIC AE30/31 SERIES PROVIDES YOU WITH EXCELLENT OPTICAL QUALITY AND UNMATCHED OPERATIONAL CONVENIENCE

COLOUR CORRECTED INFINITY OPTICAL SYSTEM

The CCIS optics allows new accessories and functions to be incorporated into the AE30/31 inverted microscope.

The CCIS infinity design has succeeded in achieving longer working distance objectives with higher numerical apertures. This represents a significant development in optical performance and versatility.



THE MICROSCOPE STAND

The design of the AE30/31 inverted microscopes optimally integrates all functions enabling effective ergonomics and maximum expandability.

The wide base provides strength and rigidity. In addition, the inverted "Y" support in the back of the microscope provides extra lateral stability.

The AE30/31 has been designed to meet the needs of demanding users. The size of the microscope is compact to minimize the footprint and conserve limited desk space available in modern laboratories.

The ergonomic design has made AE30/31 compatible with the manner in which you work. The coaxial coarse/fine focusing knobs, controls for the attachable mechanical stage and light intensity, are placed conveniently at your fingertips to minimize user fatigue. The ideally positioned focus knobs and stage controls make their manipulation stress free.



THE LIGHT SOURCE

The Koehler illumination system with a 6V-30W Quartz halogen lamp provides bright, even illumination at any magnification. The "only one in its class" centerable lamp is housed externally and has an externally operated mechanism for control of all facets of illumination. A segmented illumination intensity indicator is ideally located for easy viewing.

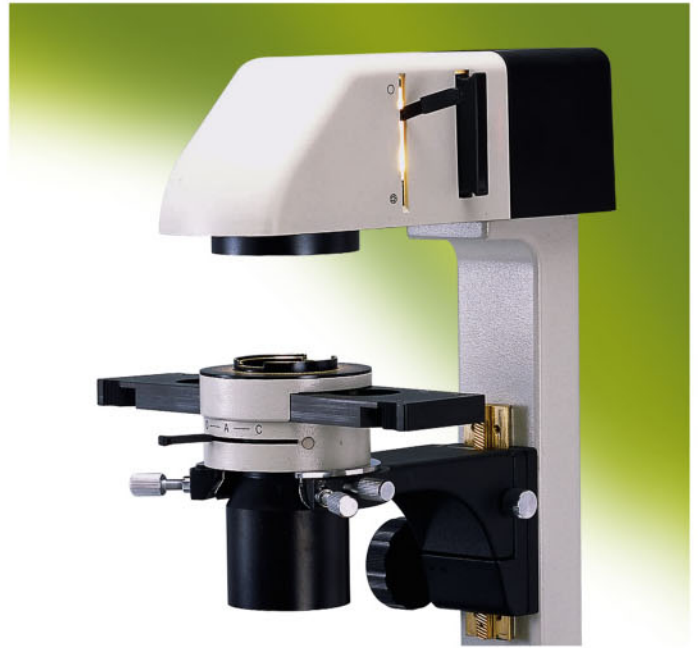
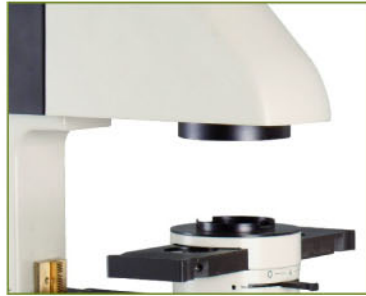

THE REVOLVING NOSEPIECE

The revolving side facing nosepiece accepts five objectives. It runs on ball bearings and has internal click stops so that the image remains centered after each change in magnification.



SPILL RESISTANT DESIGN

Internal components and optics are sealed against accidental fluid spills. This allows the user to concentrate fully on the specimen and not worry about the accidentally damaging the microscope.

The Motic AE30/31 ensures reliable and trouble-free usage.



OBSERVATION TUBES

In order to maintain parfocality, the AE30/31 Siedentopf eyepiece tubes will not change their length when interpupillary distance adjustments are made. An inclination angle of 45° is chosen for comfort and posture management.



EYEPIECES

A field of view of 22mm has now been adopted as the standard for 10X eyepieces. This enlarged field provides for faster scanning and easier viewing.

Parfocality of focus is assured by independent diopter adjustment provided on each eyepiece.

Various graticules for measurement and counting can be used with the adjustable eyepieces.



STAGE AND ACCESSORIES

The standard stage is a fixed stage plate. The stage can be widened on both sides with auxiliary stage plates. A hard coating protects the stage surface from abrasion and wear. The tempered glass stage insert allows for checking the objective being used without removing the specimen from the stage.

An optional attachable mechanical stage with low positioned coaxial controls is available. The controls are ergonomically positioned so that your hands can rest on the desk while scanning the specimen.

The object guide accepts interchangeable specimen holders: 65mm Petri dish holder (optional 35mm Petric dish holder), 54mm Petri dish holder, standard glass slides.

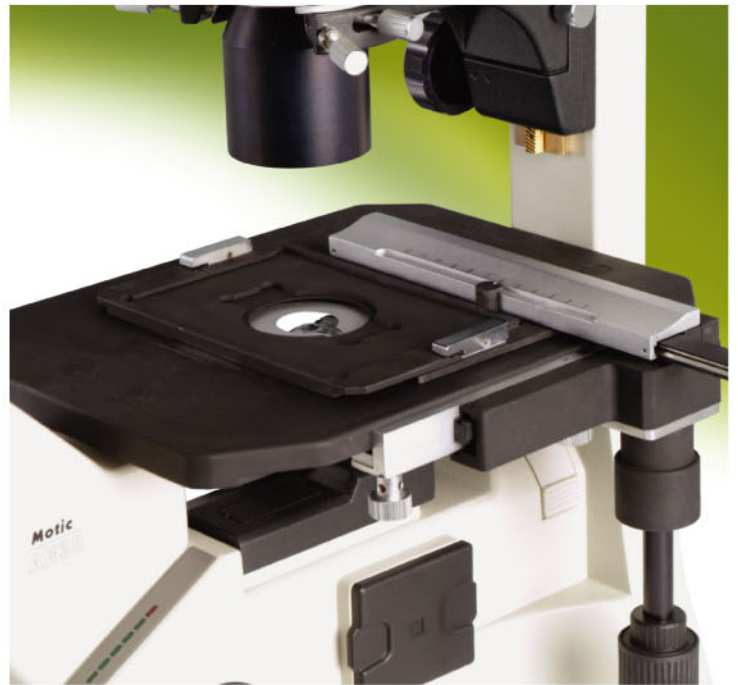

CONDENSER MOUNT

The centerable condenser mount is height adjustable with rack and pinion and is dovetail mounted on an illuminating pillar with a clamp screw.

The ELWD condenser with a numerical aperture of 0.30 and a working distance of 72mm, is suitable for objectives of magnification from 4X to 40X with an aperture diaphragm in the brightfield Koehler illumination and for phase contrast.

For easy and quick change of magnification, two annular rings on a standard non-centerable phase slider (to be released) and a centerable version, recommended for more demanding examinations, are available.

The phase annular ring Ph1 for 10X and 20X and Ph3 for 40X are centered by Allen Hex keys on the centerable slider. The center position on each slider is designated for brightfield usage.



OBJECTIVES

The Motic CCIS objectives for inverted microscopes have long free working distances in comparison to normal objectives of the same magnification. The objectives are optically corrected to compensate for different base thickness of specimen holders and provide easy routine operation.

These objectives also make it possible to turn the objective nosepiece, even at the highest magnifications, without fear of coming into contact with the object stage.

Choices of objectives:

Description	Type	N.A.	W.D. (mm)	Phase Ring
Long Working Distance Plan	PL 4X ∞	0.1	23.5	-
	PL 10X ∞	0.25	7.5	-
	LWD PL 20X ∞	0.4	7	-
	LWD PL 40X ∞	0.6	2.8	-
Long Working Distance Phase Plan Achromat	PL Ph 10X ∞	0.25	7.5	Ph1
	LWD PL Ph 20X ∞	0.4	7	Ph1
	LWD PL Ph 40X ∞	0.6	2.8	Ph3

The newly designed 20X and 40X brightfield objectives and 20X and 40X phase objectives, which compensate for a 1.1mm thick cover glass, require no cover glass compensation and provide routine operation.



PHASE CONTRAST MICROSCOPY

Phase contrast is the most popular optical contrast method for viewing the detailed structure of unstained or living specimens.

The Motic Phase Plan Achromat objectives, coupled with the easy to operate phase slider, provide outstanding contrast for the most demanding application.

For a quick and easy change of magnification, two annular rings are provided on the non-centered phase slider. The center position on the slider is designated for brightfield microscopy (to be released).

The annular rings on the centerable phase slider are centered with the provided Allen Hex keys.

DIMENSIONS INFORMATION

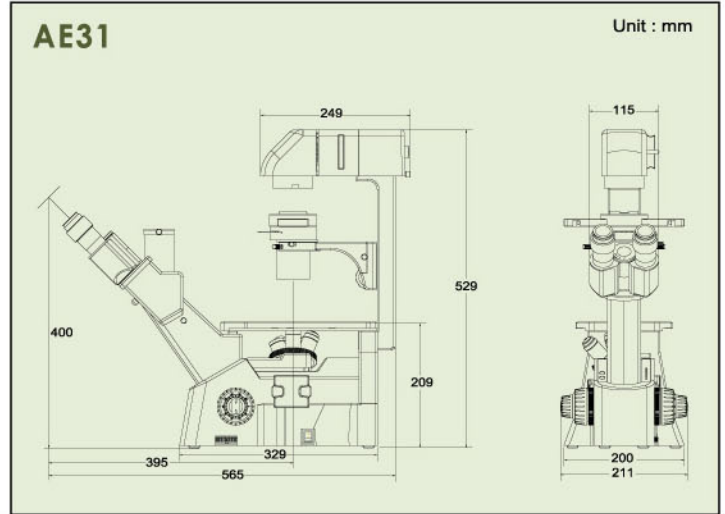
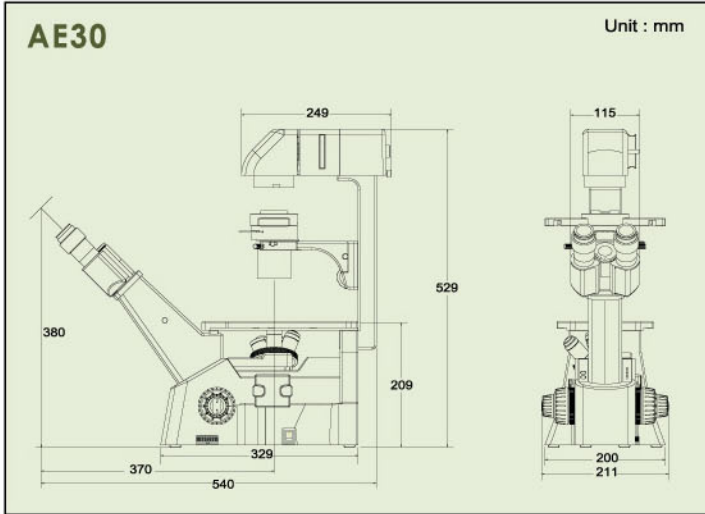

SPECIFICATIONS

	AE-30	AE-31
Optical system	CCIS (Colour corrected infinity optical system). Parfocal distance: 45mm	
Observation tubes	Siedentopf type binocular tube	Siedentopf type trinocular tube (light distribution, bino/photo:100/0 or 0/100)
	Inclination	
	45 degree	45 degree
	Interpupillary distance	
	50-75mm	50-75mm
	Eyepoint height	
	380mm from table	400mm from table
Eyepiece	Widefield High Eyepoint WF PL10X (FN 22) with diopter adjustment	
Nosepiece	Quintuple nosepiece, side facing type	
Plain stage	Stage size: 200 x 260mm. Stage height: 207mm from table.	
Focusing	Coaxial / via nosepiece Up / down movement Coarse / fine movement - 42mm / 0.2mm Min. fine reading 2µm. Adjustable coarse torque	
Illumination	6V-30W Quartz halogen centerable lamp is housed externally and has an externally operated device for all the elements of illumination with built-in heat absorbing filter and removable diffuser	
Condenser	ELWD N.A. 0.30 (W.D. 72mm) Focusable LWD N.A. 0.50 (W.D. 28mm) Focusable for objective 4X to 40X	
Collector	Aspherical lens with field diaphragm	

STANDARD & OPTIONAL SET CONFIGURATION

Specifications		Order No.	AE30	AE31
Eyepieces	Widefield High Eyepoint	WF PL 10X/22 with diopter adjustment	SG02S0144	● ●
CCIS Infinity Objectives	LWD Phase	CCIS PL Ph10X	SG01S02291	● ●
		CCIS LWD PL Ph20X	SG01S03291	● ●
		CCIS LWD PL Ph40X	SG01S04291	● ●
	LWD Plan	CCIS PL4X	SG01S01241	● ●
		CCIS PL10X	SG01S02241	○ ○
		CCIS LWD PL20X	SG01S03241	○ ○
		CCIS LWD PL40X	SG01S04241	○ ○
	CCIS LWD PL60X	SG01S05241	● ●	
Condenser	ELWD N.A. 0.30 (W.D. 72mm)		SG030401A	● ●
	LWD N.A. 0.5 (W.D. 28mm)		SG030701	○ ○
Phase Slider	Centerable: Ph1, Ph3, One empty position		SW0123F8	●* ●*
	Non-centerable - Ph1, Brightfield, Ph3 (to be released)			
Phase Contrast Accessories	Phase Centering Telescope (∅30)		SG069993	●* ●*
Photo Adapters	Photo Adapter (requires one of the photo eyepiece below)		SP100294	/ ○
	2.5X Photo eyepiece		SG02S1001	/ ○
	4X Photo eyepiece		SG02S1101	/ ○
Video Adapters	CCD adapter 0.65X		SP100384	/ ○
	CCD adapter 1X		SP100350	/ ○
Stage & Accessories	Glass stage insert		SP100301	● ●
	Metal stage insert		SW0199F9	● ●
	Auxilliary stages (paired set)		SW0123G3	○ ○
	Universal attachable mechanical stage with well plate holders		SW010392	○ ○
	35mm Petri dish holder		SP100303	○ ○
	54mm Petri dish holder		SP100304	○ ○
	65mm Petri dish holder		SP100302	○ ○
Filters	Green interference (45mm diameter)		SG060747	● ●
	Blue filter (45mm diameter)		SG060727	● ●
	Ground glass (45mm diameter)		SG060729A	● ●
Allen Hex. Key	Two keys provided		SP070014	●* ●*

Note: "●" represents the standard accessories, "○" represents the optional accessories.
 "*" to be used with phase objectives,
 "●" represents the optional accessories for some markets.
 Please check with your local Motic Agent

AE30/31 INVERTED MICROSCOPES SYSTEM DIAGRAM

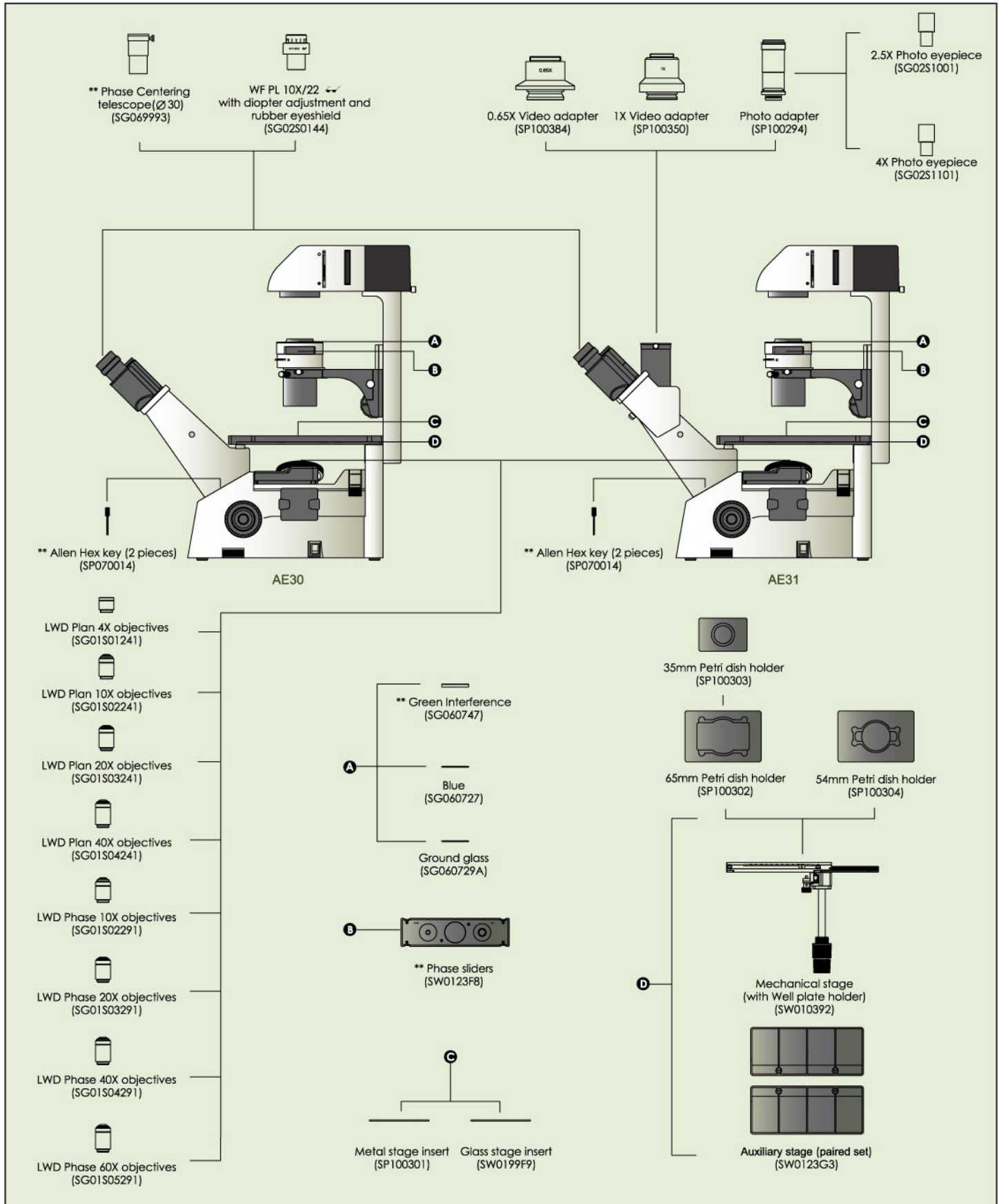

Note: " ** " to be used with phase objectives